



DIMENSIONI / DIMENSIONS (mm)

CODICE XX CODE	02	03	04	05	06
CARICO [Kg] LOAD	10	20	50	100	200
MATERIALE MATERIAL	Alluminio Aluminium			Acciaio Inox 17-4 PH Stainless steel 17-4 PH	

Se non diversamente indicato le tolleranze sono $\pm 0,1$ mm

If not specified, tolerances are $\pm 0,1$ mm

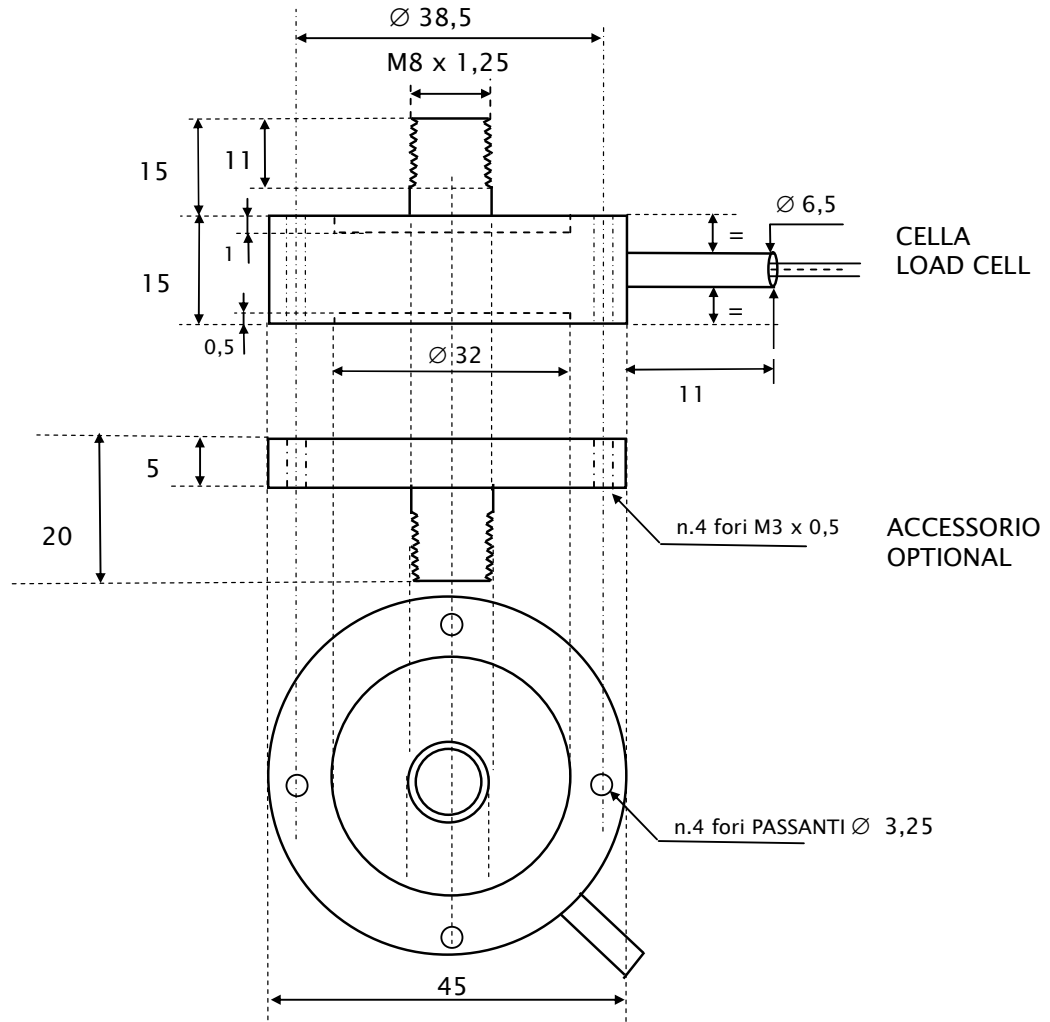

**DATI TECNICI / TECHNICAL DATA**

CARICO NOMINALE	NOMINAL LOAD	10- 20-50-100- 200 Kg
SENSIBILITA' NOMINALE	NOMINAL SENSITIVITY	2 mV/Volt
TOLLERANZA DI CALIBRAZIONE	SENSITIVITY TOLERANCE	≤ ± 0,1%
RIPETIBILITA'	REPEATABILITY	± 0.1 F.S.
COEFFICIENTE TEMPERATURA DI ZERO	ZERO TEMPERATURE COEFF.	± 0.005 % F.S/°C
COEFFICIENTE TEMPERATURA DI F.S.	SPAN TEMPERATURE COEFF.	± 0.008 % F.S/°C
RESISTENZA DI INGRESSO	INPUT RESISTANCE	350 ± 20 Ω
RESISTENZA DI USCITA	OUTPUT RESISTANCE	350 ± 5 Ω
RESISTENZA DI ISOLAMENTO	INSULATION RESISTANCE	> 5000 MΩ
BILANCIAMENTO	ZERO BALANCE	± 1 %
ALIMENTAZIONE DI RIFERIMENTO	RECOMMENDED SUPPLY VOLTAGE	5 Vcc/ca
ALIMENTAZIONE NOMINALE	NOMINAL RANGE OF EXCITATION VOLTAGE	2-15 Vcc/ca
VALORI MECCANICI LIMITE RIFERITI AL CARICO NOMINALE	MECHANICAL LIMIT VALUES RELATED TO NOMINAL LOAD	
a. carico di servizio	a. service load	120 % F.S.
b. carico limite	b. max permissible load	120 % F.S.
c. carico di rottura	c. breaking load	>200 %F.S.
d. massimo carico trasversale	d. maximun side load	10 % F.S.
FRECCIA MASSIMA AL CARICO NOMINALE	DEFLECTION AT RATED CAPACITY	0.5 mm
TEMPERATURA DI RIFERIMENTO	REFERENCE TEMPERATURE	+ 23 ° C
CAMPO NOMINALE DI TEMPERATURA	NOMINAL TEMPERATURE RANGE	-10 / +50 ° C
CAMPO DELLE TEMPERATURE DI ESERCIZIO	SERVICE TEMPERATURE RANGE	-20 / +70 ° C
PESO	WEIGHT	60-80 g
CLASSE DI PROTEZIONE (DIN 40050)	PROTECTION CLASS (DIN 40050)	IP 65
MATERIALE DELLA CELLA	CELL MATERIAL	Alluminio / Alluminium (Acciaio inox/Stainless Steel)
LUNGHEZZA CAVO	CABLE LENGHT	1 m

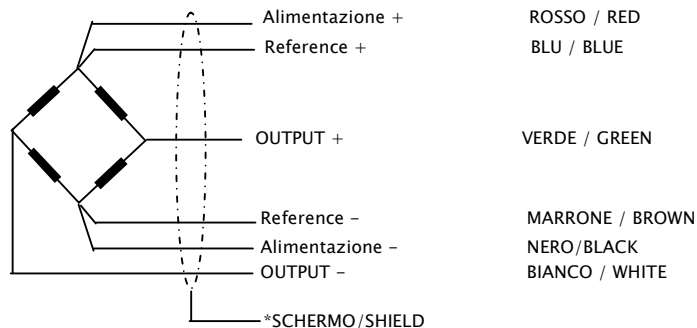
COLLEGAMENTI ELETTRICI / ELECTRICAL CONNECTIONS

*SCHERMO non collegato al corpo della cella di carico.
SHIELD not connected to the load cell body